

TOP PIVOT & DOOR PREP.
NOT TO SCALE

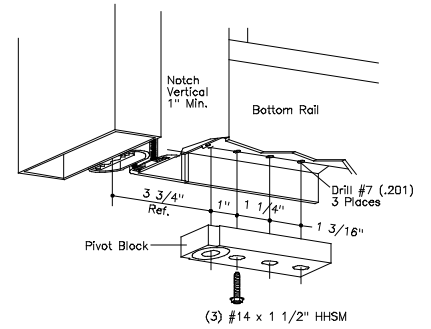

BOTTOM PIVOT & DOOR PREP.
NOT TO SCALE

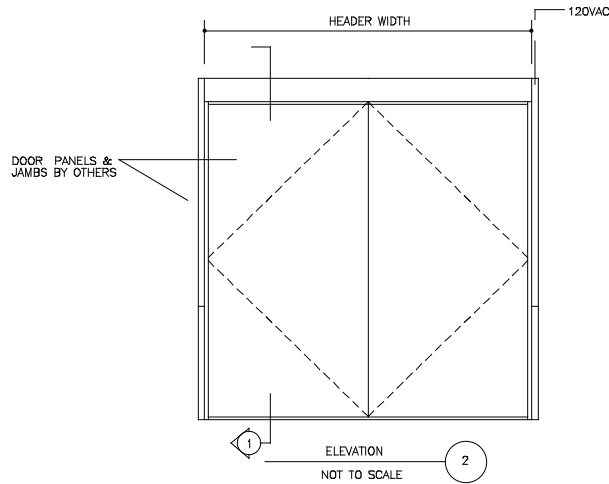

NOTE : LHR-RHR (exterior swing) shown. For Interior swing, specify LH-RH.

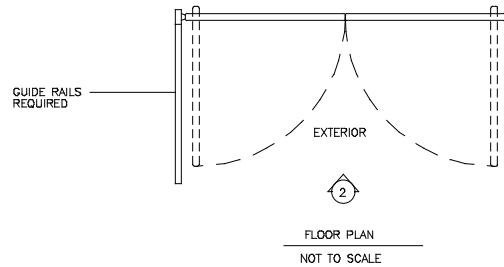

File 4.061d1
Horton Series 4800
Overhead Concealed Operator