

DORMA Automatics, Inc
 924 Sherwood Drive 60044
 Lake Bluff, Illinois
 Toll Free: (877)-367-6211
 Fax: (877)423-7999

THE STANDARD PACKAGE CONSISTS OF:
 THE AUTOMATIC SWING DOOR OPERATOR & HOUSING, ARM,
 CONTROLLER, MOUNTING HARDWARE, CONCEALED CONTROL
 PANEL (OFF, AUTO, HOLD-OPEN)
 STANDARD FINISHES: CLEAR BHMA 204
 DARK BRONZE BHMA 313

DRAWING DIMENSIONS ARE IN ENGLISH AND
 METRIC UNITS. METRICS ARE SHOWN IN
 MILLIMETERS, AS FOLLOWS: 1" (25.4)
 FOR MAXIMUM CURRENT DRAW, SEE PRODUCT
 SPECIFICATION OR INSTALLATION INSTRUCTIONS.

REFER TO APPLICABLE LOCAL, STATE OR NATIONAL
 BUILDING CODE FOR MINIMUM DOOR HEIGHTS AND
 WIDTHS FOR ALLOWABLE EGRESS REQUIREMENTS.
 SEE REFERENCE TABLE.

STANDARD OPERATOR SIZES	
DOOR WIDTH	OVERALL OPERATOR WIDTH
36" (914)	39" (990)
42" (1066)	45" (1142)
48" (1219)	51" (1295)

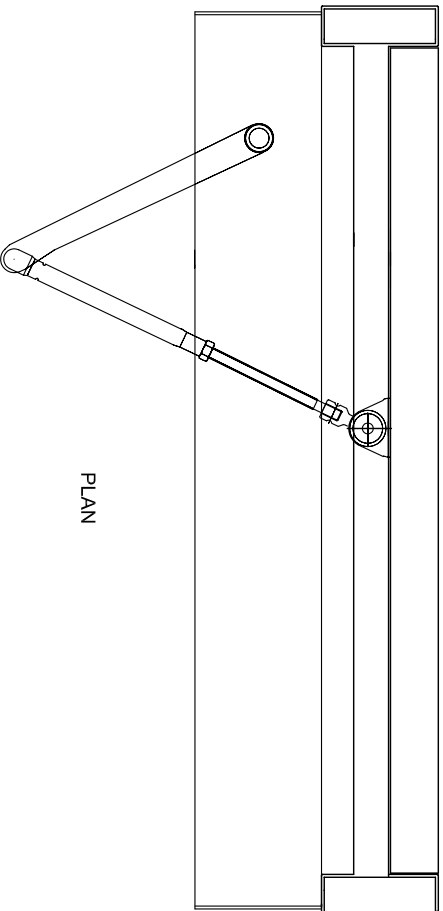

PLAN

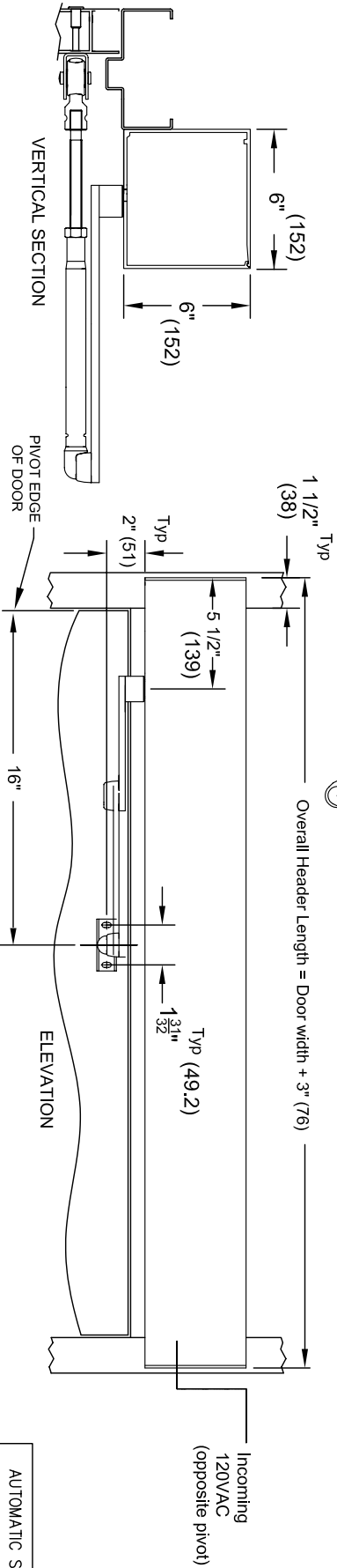

Note: Dimensions in () are mm

AUTOMATIC SWINGING DOOR
 ED 400 SERIES - SINGLE
 HOLLOW METAL DOOR
 "PUSH" ARM 3/06

Incoming
 120VAC
 (opposite pivot)