

CRANE
Revolving Doors

KTC Line



DORMA Entrance Systems™



Make a big statement with your entrance

Attractive, functional and practical, DORMA KTC Series large-diameter automatic revolving doors from Crane™ combine modern styling with proven performance. Offered in outside diameters up to 21 feet—among the widest in North America—DORMA's KTC Series doors are available in a variety of configurations and programming options to meet your most demanding installations.

Unmatched versatility

To meet a wide range of applications, DORMA's KTC Series doors are available in two-, three- and four-wing models with outside diameters from 12' 6" to 21'. Summer configurations enable doors to collapse inward for unobstructed flow or passage of bulky items. And optional locked wings and night shields can be selected for increased security.

Leave a memorable first impression

KTC Series revolving doors feature European styling steeped in simplicity and elegance. Graceful curved drum walls, narrow framing and concealed mechanics provide a sleek, clean

appearance. Select from dozens of materials and surfaces finished to match almost any facade. You can also opt for glass-enclosed display showcases for additional visual appeal.

All the benefits of a revolving door—and then some

KTC Series doors help protect your building interior from drafts, noise and dirt. In minimizing airflow between the outside and inside, a revolving door will usually pay for itself in energy savings within a three-to-five year window. KTC Series revolving doors help pedestrians move in and out of the building, managing high traffic volumes without difficulty. And all KTC Series doors offer ultra-modern safety and security systems for your peace of mind.

Ideal for use in:

- Hotels
- Healthcare settings
- Airports and transportation facilities
- Commercial office buildings
- Institutional and educational buildings
- Retail stores

Benefits of DORMA KTC Line

For installers

- Tailored to suit widely differing structural conditions
- Trouble-free installation and commissioning
- Most up-to-date technology conforming to relevant national and international standards

For architects and designers

- Comprehensive product range includes solutions suitable for sophisticated and prestigious entrances.
- High degree of design flexibility thanks to a wide range of modular components

- Problem-free adaptability to individual requirements
- Visually, technically and economically convincing solution

For end-users

- Integrated system manufactured with industrial precision and assured quality
- Optimization of the building energy balance and workplace environment
- Exceptional user convenience
- Outstanding safety features

Data and Features	DORMA KTC-2	DORMA KTC-3	DORMA KTC-4
Internal diameter	11'-10", 13'-9", 15'-9"	13'-9", 15'-9", 17'-9", 19'-9"	13'-10", 15'-9", 17'-9", 20'-4"
External diameter	12'-7", 14'-6", 16'-6"	14'-6", 16'-6", 18'-6", 20'-5"	14'-6", 16'-11", 18'-6", 21'-1"
Clear passage width	5'-5", 6'-5", 7'-4"	6'-5", 7'-4", 8'-4", 9'-4"	9'-6", 10'-11", 12'-3", 14'-2"
Clear escape passage width	Equal to clear passage width	up to 15'-9" dia.: 7'-3"-8'-2"; from 17'-9" dia.: 7'-3"	up to 15'-9" dia.: 7'-3"-8'-2"; from 17'-9" dia.: 7'-3"
Clear passage height	6'-11"-7'-7"**	1'-4"-2'-4"	1'-4"-2'-4"
Canopy height	1'-4"-2'-4"	up to 10'-6"	up to 10'-6"
Total height	Clear passage height + canopy height		
Side walls glazed	○	○	○
Side walls with metal paneling	○	○	○
Suitable for escape routes	○	○	○
Slow Stop	•	•	•
Floor ring	•	•	•
Floor mat	○	○	○
Downlights	4	6	8
Prepared for rainproof roof	○	○	○

• Yes ○ Option











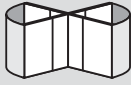

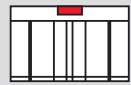
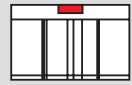
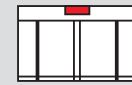





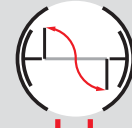

*larger clear passage heights on demand



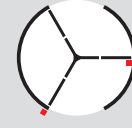





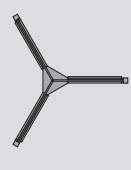

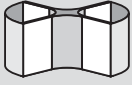





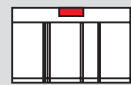
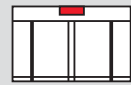











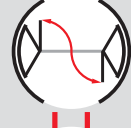
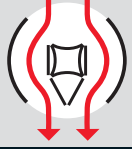

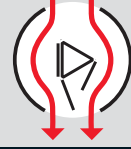
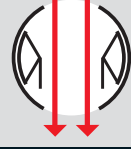
Note: The DORMA KTC Line is a metric product with U.S. conversions.

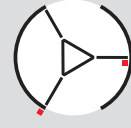
Traffic Capacities

Inside diameter	Theoretical capacity	Practical capacity		Maximum capacity
	Persons/hour One-way	Persons/hour One-way	Two-way	Persons/minute One-way
KTC-2				
11'-10"	2160	720	1440	36
13'-9"	2880	960	1920	48
15'-9"	3600	1200	2400	60
KTC-3				
11'-10"	2916	972	1944	48
13'-9"	3312	1104	2208	55
15'-9"	4320	1440	2880	72
17'-9"	4536	1512	3024	75
19'-8"	5184	1728	3456	86
KTC-4				
11'-10"	2592	864	1728	43
13'-9"	3312	3312	2208	55
15'-9"	3840	3840	2560	64
17'-9"	4320	4320	2880	72
20'-4"	5208	5208	3472	86

Designs, functions, standard equipment, optional extras

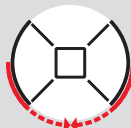
Models			
KTC-4/0		KTC-3/0	
	Four wings and standard core		Three wings and standard core
			
			Two wings without showcase
Operator Types			
Ceiling-integral drive unit			
Automatic Operation			
<ul style="list-style-type: none"> Door starts/stops automatically Continuous rotation at low speed is increased when a user approaches the door 			
Speed reduction feature Decreases to ~2 rpm e.g. for seniors, disabled persons			
Configurations			
Summer configuration Also ideal for the passage of bulky items or luggage, and for consignment deliveries			
Emergency escape configuration			
Options			
Manually or electrically locked wings			
Sliding night shields, internal			
Sliding night shields, external			
Core Configuration			
			

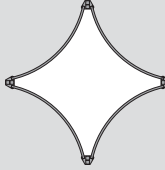
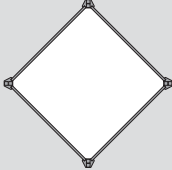
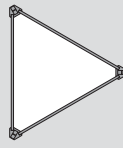
Models			
<p>KTC-4/1</p>  <p>Four wings and a central showcase with curved glass panels</p>	<p>KTC-4/2</p>  <p>Four wings and a central showcase with straight glass panels</p>	<p>KTC-3/2</p>  <p>Three wings and a central showcase with straight glass panels</p>	<p>KTC-2/2</p>  <p>Two wings with outlying triangular showcases</p>
Operator Types			
			
Automatic Operation			
			
			
Configurations			
			
			
Options			
			
			
			
Core Configuration			
			

Two-Wing Design

DORMA KTC-2 revolving doors are available in three standard sizes. They feature two breakout wings with an integrated night shield fitted with safety glass. The drum walls can either be glazed or provided with metal paneling. The KTC 2/2 model is provided with two outlying triangular showcases.

Three-Wing Design

DORMA KTC-3 revolving doors are available in 4 standard sizes. The 3-wing revolving doors are available with various accessories. The breakout wings with their catch and pivot fittings are equipped with horsehair brushes in order to ensure the reliable exclusion of drafts in the entrance area.

Central part versions

- Without showcase
- With straight glass panel showcase

Drum wall versions

- Without night shield
- With manually operated external night shield
- With manually or electrically operated internal night shield

KTC-2/O (without showcases)

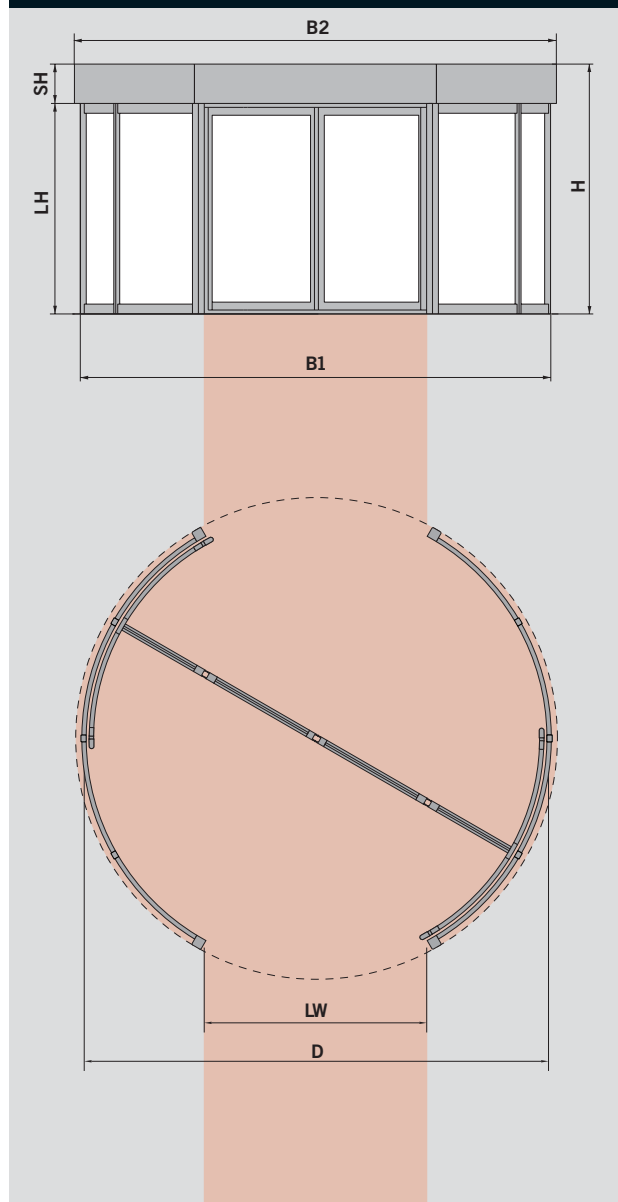

KTC-3/O (without showcases)

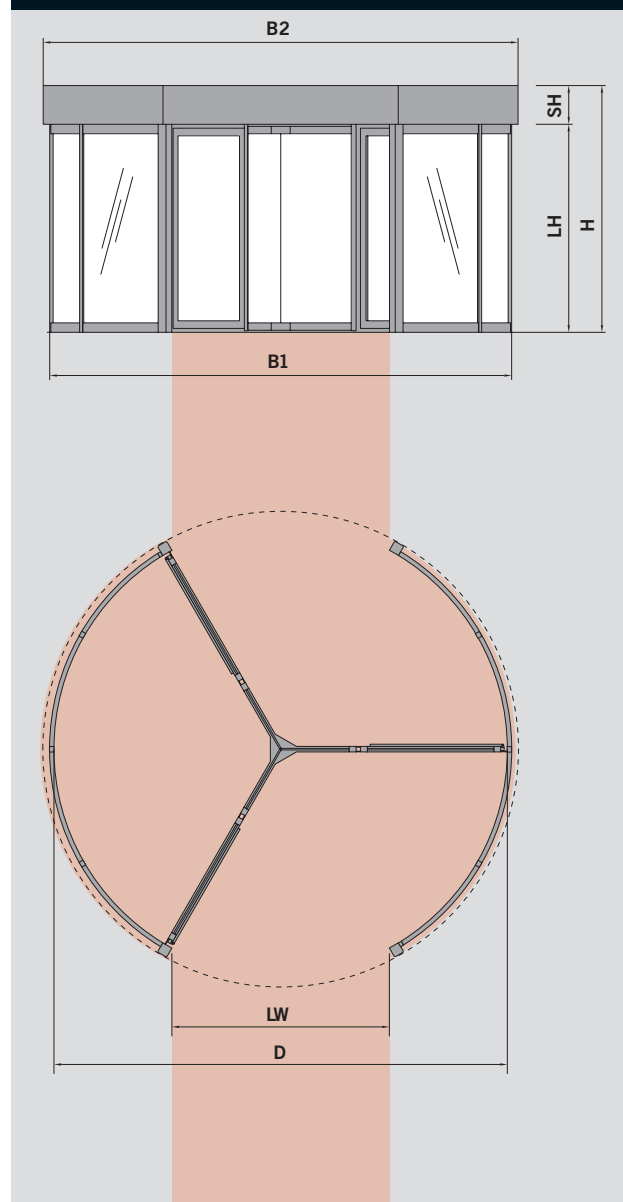

Four-Wing Design

DORMA KTC-4 revolving doors are available in 4 standard sizes. The 4-wing revolving doors are available with various accessories. The breakout wings with their catch and pivot fittings are equipped with horsehair brushes in order to ensure the reliable exclusion of drafts in the entrance area.

Central part versions

- Without showcase
- With straight glass panel showcase
- With curved glass panel showcase

Drum wall versions

- Without night shield
- With manually operated external night shield
- With manually or electrically operated internal night shield

Dimensions, KTC-2

Internal diameter (D)	11'-10", 13'-9", 15'-6"
External diameter (B1)	12'-1", 14'-1", 16'-1"
External diameter (B2)	12'-7", 14'-6", 16'-6"
Clear passage width (LW)	5'-4", 6'-4", 7'-4"
Clear passage height (LH)	6'-11"-7'-7"*
Canopy height (SH)	1'-4" to 2'-4"
Total height (H)	Clear passage height + canopy height

*larger clear passage heights on demand.

KTC-4/0 (without showcases)

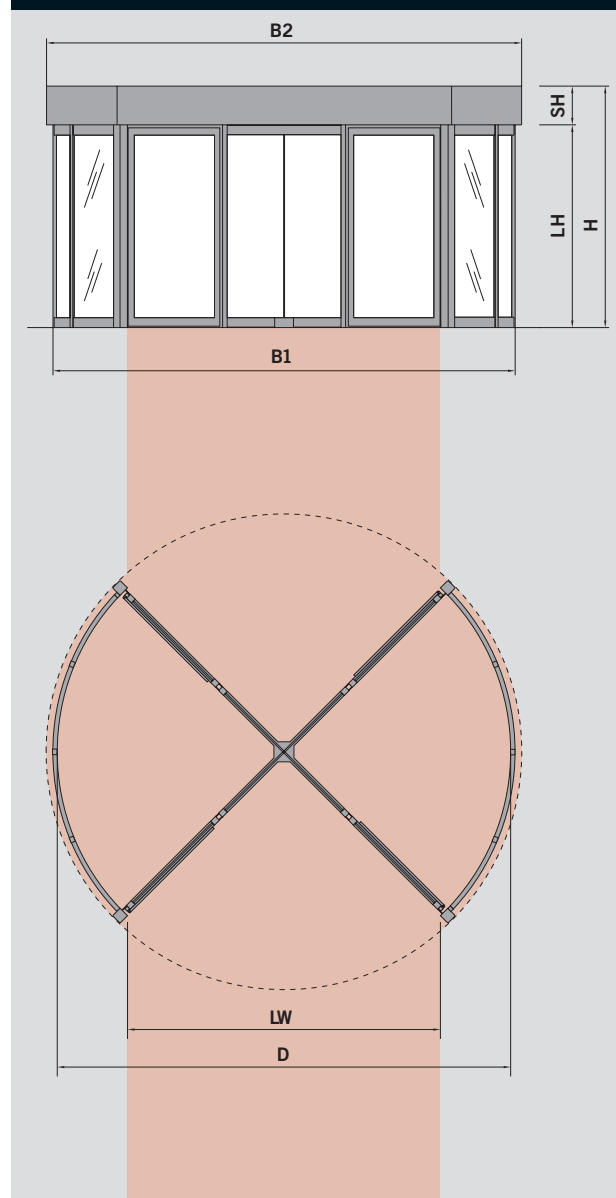

Dimensions, KTC-3

Inside diameter (D)	13'-9"	17'-9"
	15'-9"	19'-9"
Outside diameter (B1)	14'-1"	18'
	16'-1"	19'-12"
Outside diameter (B2)	14'-7"	18'-6"
	16'-6"	20'-5"
Clear passage width (LW)	6'-5"	8'-4"
	7'-4"	9'-4"
Escape passage width	3'-11"	5'-2"
	4'-7"	5'-10"
Clear passage height (LH)	up to 8'-2"*	up to 7'-3"*
Total height (H)	up to 10'-6"*	up to 9'-6"*
Canopy height (SH)	1'-4" to 2'-4"*	

* Other heights on application.

Dimensions, KTC-4

Inside diameter (D)	13'-9"	15'-9", 17'-9", 20'-4"
Outside diameter (B1)	14'-1"	16'-1", 18', 20'-8"
Outside diameter (B2)	14'-6"	16'-6", 18'-6", 21'-1"
Clear passage width (LW)	9'-6"	10'-11", 12'-3", 14'-2"
Escape passage width	3'-6"	4'-1", 4'-7", 5'-4"
Clear passage height (LH)	up to 8'-2"*	up to 7'-3"*
Total height (H)	up to 10'-6"*	up to 9'-6"*
Canopy height (SH)	1'-4" to 2'-4"*	

* Other heights on application.

Floor Ring, KTC-2

Installation size (Internal diameter of door set)	11'-10"	13'-9"	15'-9"
Nominal radius (R)	5'-11"	6'-11"	7'-11"
Floor mat (C)		up to 1'	

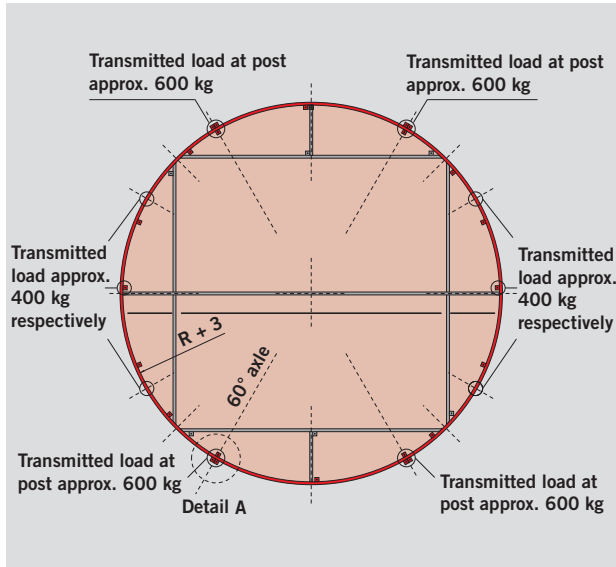

Floor Rings, KTC-3/KTC-4

Diameter		13'-9"	15'-9"	17'-9"	(19'-8" ¹)	(20'-4" ²)
Sub-floor to FFL (A)	3"					
Nominal radius (R)		6'-11"	7'-11"	8'-10"	9'-10"	10'-2"
Floor mat (C)	up to 1'					

¹ KTC-3 only

² KTC-4 only

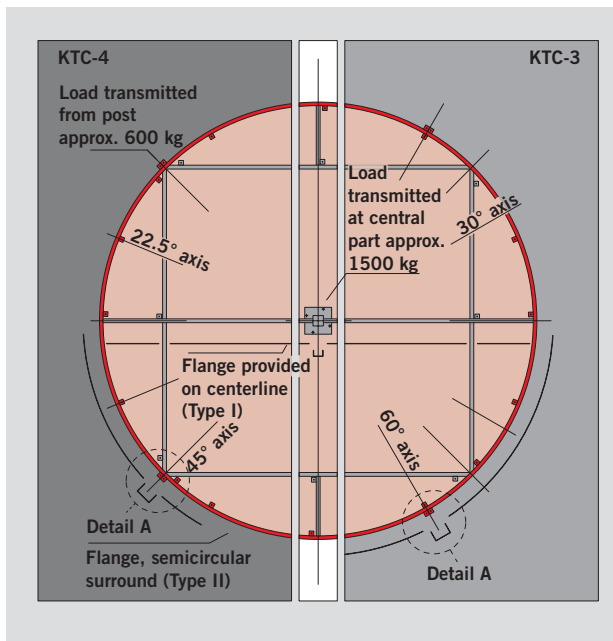

Safety Equipment, KTC-2

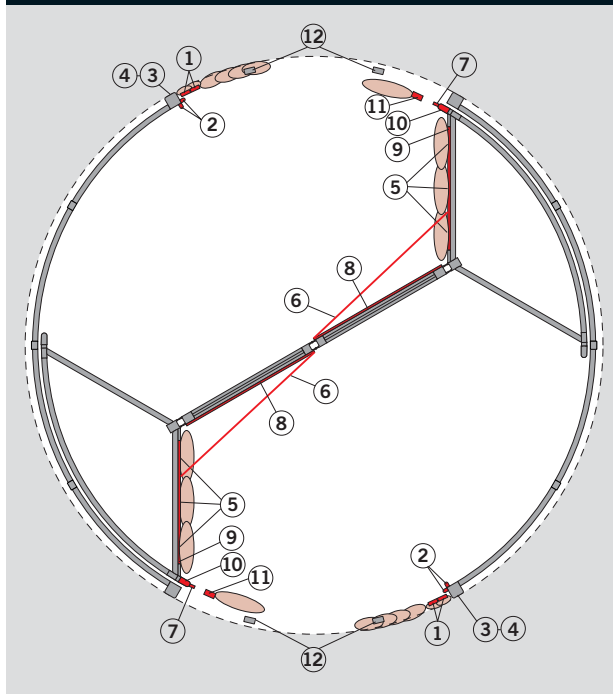

DORMA KTC-2 revolving doors offer a comprehensive range of safety equipment to ensure optimum protection of people and objects as they pass through the entrance/exit system. The main closing edges are each equipped with two infrared safety sensors and safety contact strips. As the showcase section arrives at a point 1'-8" from the upright post at the end of the drum wall, the infrared safety sensors and the safety contact strips are activated. The vertical outer edges of the night shield are likewise protected by safety contact strips. The internal area is monitored with the aid of an infrared light curtain. This detects the presence of any person or object that is moving too slowly for the revolving assembly, and will reduce the operating speed accordingly. If a door wing meets an obstruction, the door is stopped until the obstruction has been removed. Additional sensors are integrated into the canopy, which scan the range in front of the night shield. The detection range is located in front of the main closing edge, from the canopy to approx. 1'-4" above the floor.

- ① Canopy sensors, infrared safety sensors monitoring the range between canopy and floor
- ② Safety contact strips on posts and safety contact strip, inside of posts (shearing protection)
- ③ Disabled access pushbutton
- ④ Emergency off pushbutton
- ⑤ Slow stop sensors
- ⑥ Light barrier monitoring bottom edge of door wing (optional)
- ⑦ Infrared safety sensor in the floor area (optional)
- ⑧ Safety contact strips, wing bottom, horizontal
- ⑨ Safety contact strips, showcase bottom, horizontal
- ⑩ Safety contact strips, outer edge of night shield, vertical
- ⑪ Infrared safety sensor, leading edge of night shield, (stop)
- ⑫ Infrared safety sensor, night shield, leading edge (creep mode)
- ⑬ Motion detector

Safety Equipment, KTC-3/KTC-4

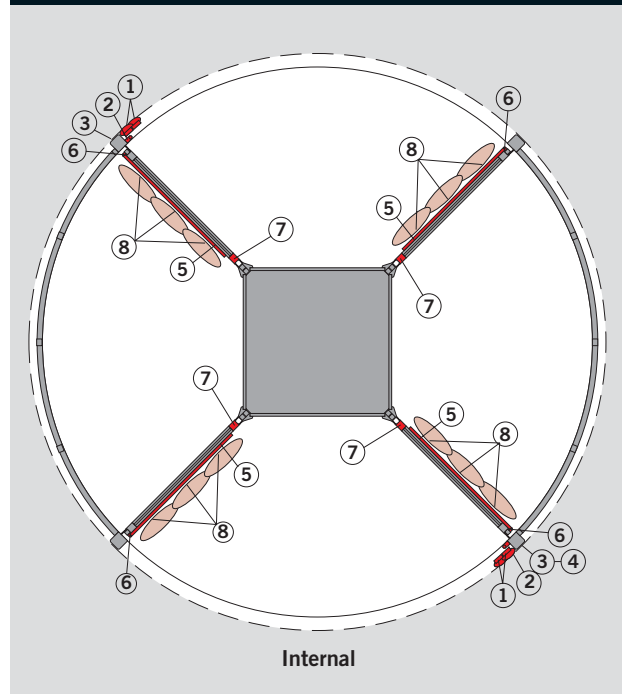

DORMA KTC-3/KTC-4 revolving doors offer a comprehensive range of safety equipment to ensure optimum protection of people and objects as they pass through the entrance/exit system. The main closing/shear edges are each equipped with two infra-red detectors and a safety contact strip. As a wing arrives at a point 1'-8" from the upright post at the end of the drum wall, the infra-red light detectors and the contact strips on the post are activated. The outer edges and the bottom edges of the wings are likewise protected by safety contact strips. In addition, the wings fold on contact. As an optional extra, sensors can be provided on the top wing profile to protect the space in front of the wing.

- ① Canopy sensors, 2 x 2 infra-red detectors
- ② Post sensors in the form of 2 contact strips
- ③ Disabled access push-buttons, inside and out
- ④ Emergency stop push-button, inside
- ⑤ Contact safety strip, wing bottom, horizontal
- ⑥ Contact safety strip, wing, vertical
- ⑦ Limit switches, wings
- ⑧ Wing top sensors, horizontal (optional extra)

Wiring Diagram

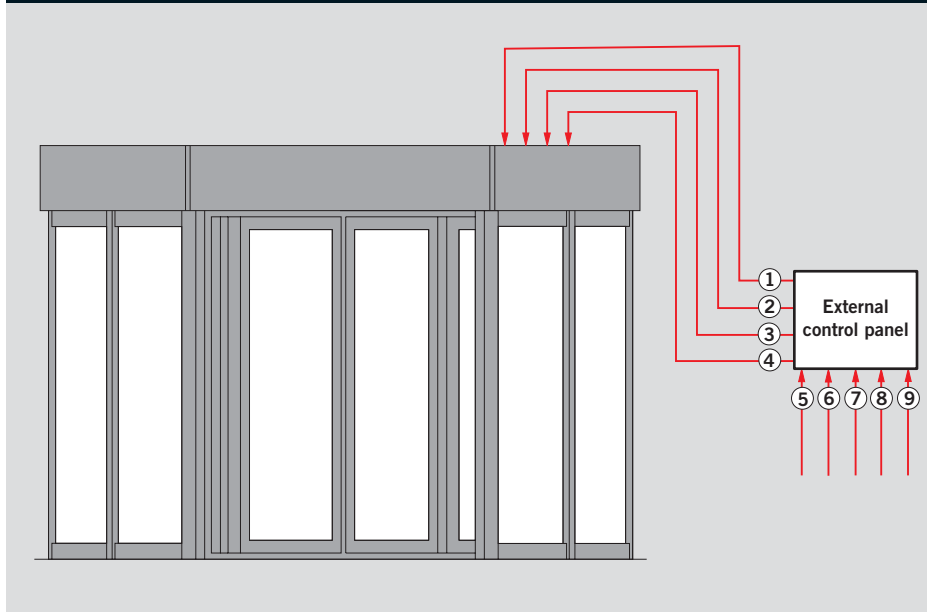

- ① Control unit, 25 x .03"
- ② Control unit, 25 x .03"
- ③ Emergency power supply unit 4 x .1"
- ④ Motor, 3 x .1", screened
- ⑤ Lighting control, 2 x .002"
- ⑥ Group alarm, 2 x .002"
- ⑦ Fire detector contact, 2 x .002"
- ⑧ Remote control for locking device, 3 x .002"
- ⑨ Power supply, 230 V, 50 Hz, 10A, 3 x .06"

Control Panel, External
 Height 31.5"
 Width 23.62"
 Depth 10.24"

Electrical Cabling

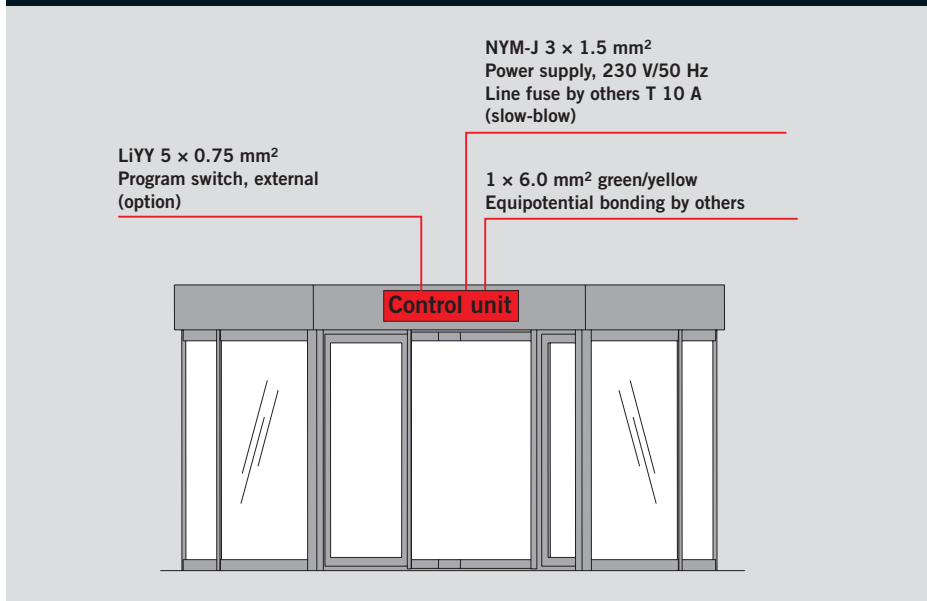

Optional Finishes

- Clear Anodized
- Bronze/Brass
- Stainless Steel

Custom finishes available.
 Contact factory for available finish options.

Automatic Modes / Speed Reduction Feature

- The automatic control system offers two operating modes:
 - Automatic I – The stationary door is activated as soon as a user approaches. Following an adjustable time, it stops again at its starting position.
 - Automatic II – The door rotates continuously at approx. 1 rpm. As a user enters the detection range, the speed is increased to approx. 3 rpm. Once the user has left the detection range, the speed of the door is reduced again.
- The speed reduction feature is activated by means of a special pushbutton to reduce the speed of the door during passage to approx. 2 rpm.

DORMA KTC line ideal for hospitality and healthcare applications

DORMA KTC Series Automatic Revolving Doors can be used in a variety of applications. However, two of the most common venues are hospitality and healthcare, where the automatic action of the doors can greatly simplify passage for pedestrians.



Hotels and Hospitality

KTC Series Revolving Doors can be configured to meet the specific needs of your hotel or hospitality venue. Their striking appearance and reliable functionality will meet aesthetic needs of the entryway while allowing easy movement in and out of the facility. KTC Series doors can accommodate high traffic volumes in addition to luggage, making it ideal for convention centers and hotels where guests cart their own bags.



Hospitals and Healthcare

Hospitals and healthcare facilities present unique challenges for revolving doors. Patients that use wheelchairs and crutches usually do not have the ability to push a door open. Plus, they need more room to navigate entryways. And revolving doors must often accommodate a patient and caregiver or personal assistant simultaneously. DORMA KTC Automatic Revolving Doors offer field-adjustable speed control and a host of safety features to ensure pedestrian safety throughout the door cycle. All doors comply with ANSI 156.27 standard safety regulation for pedestrian revolving doors. Of course, all of this performance comes with Crane's renowned durability and lasting beauty.

Renowned for durability and quality craftsmanship, Crane manual, automatic, and security revolving doors can be found in thousands of buildings worldwide.



Design and Technical Support

Up to date details and specifications for Crane products are available to architects and customers at www.cranedoor.com and in our printed detail book.

DORMA Group North America manufactures and markets a wide range of products for the architectural openings industry, with a particular focus on commercial and institutional openings. Part of the DORMA Group Worldwide, DORMA Group North America is comprised of DORMA Architectural Hardware, DORMA Glas, Modernfold, DORMA Canada, DORMA Mexico, and DORMA Entrance Systems—which markets products and services under the DORMA Automatics, Crane Revolving Doors™, and Carolina Door Controls brands.

Crane Revolving Doors and Crane are trademarks of DORMA Group North America.

© 2006 DORMA Group North America.
Printed in U.S.A. 12.06

CRANE Revolving Doors

DORMA Group North America
DORMA Entrance Systems

924 Sherwood Drive
Lake Bluff, IL 60044

Tel: (800) 942-7263
Toll Free: (847) 295-2700
Fax (847) 295-5288

sales@cranedoor.com
www.cranedoor.com