

1 Elevation

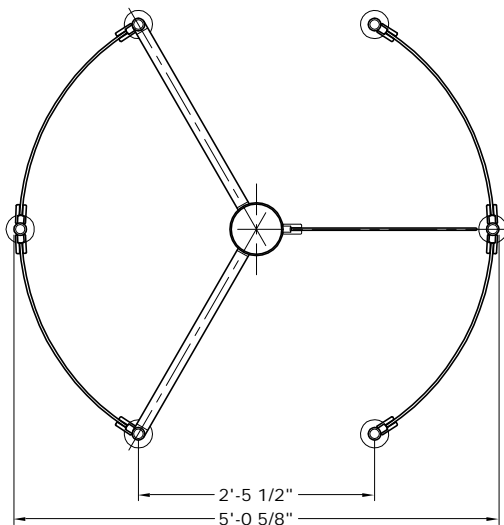

2 Plan View

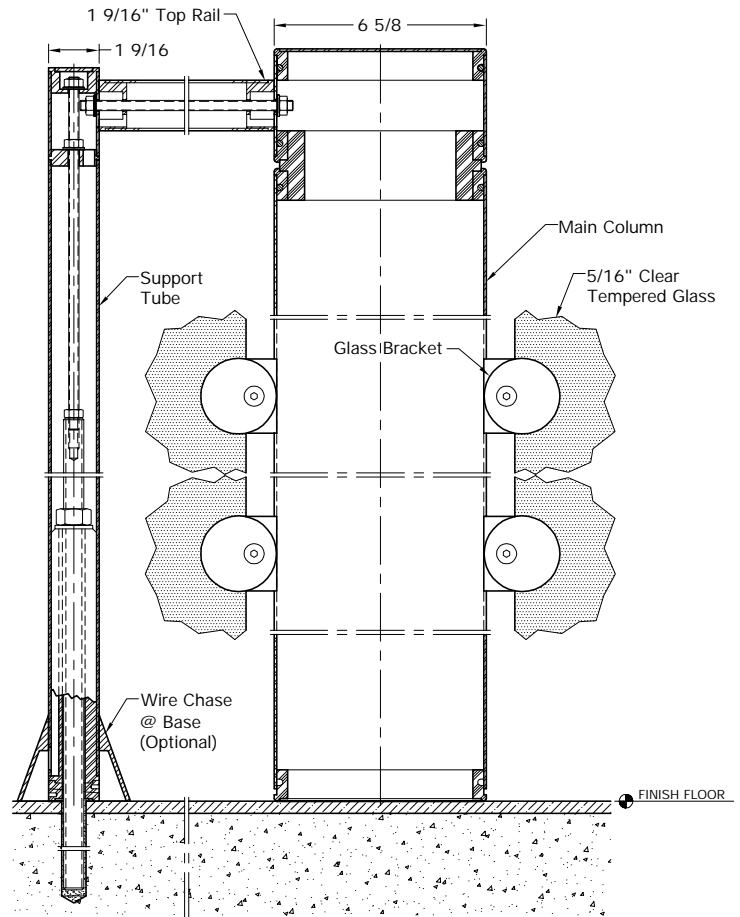

3 Vertical Sections

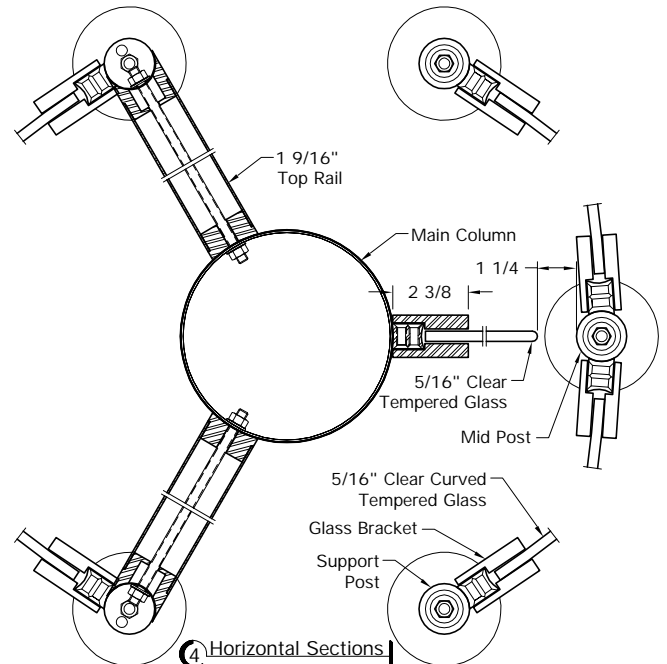

4 Horizontal Sections

Installation:

Turnstile Installs on Finish Floor (No recess, rings, or cutouts required)
Floor Must be Dead Level.
Power Supply from Floor.